

GEM P TRIMLESS INSTALLATION INSTRUCTIONS

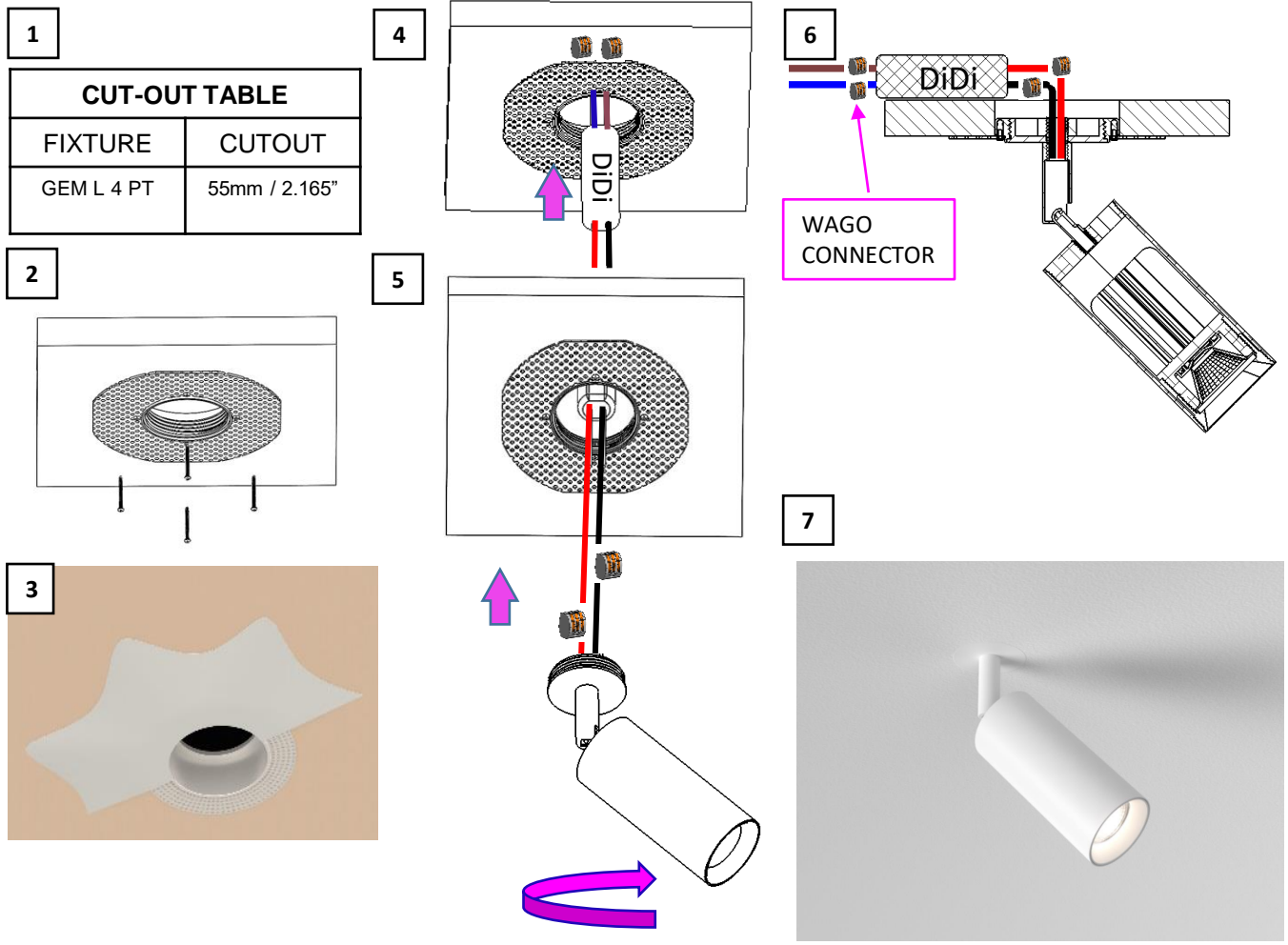

WARNING - RISK OF FIRE AND ELECTRICAL SHOCK. FIXTURE MUST BE INSTALLED BY A QUALIFIED ELECTRICIAN ONLY. FIXTURE IS INTENDED FOR INSTALLATION IN ACCORDANCE WITH THE NATIONAL ELECTRICAL CODE, LOCAL AND FEDERAL SPECIFICATIONS. DISCONNECT POWER AT ELECTRICAL PANEL BEFORE SERVICING. RETAIN THESE INSTRUCTIONS FOR MAINTENANCE REFERENCE.

FIXTURE INSTALLATION – LOW VOLTAGE



1. CUT A HOLE PER THE CEILING CUTOUT TABLE.(FIGURE 1)
2. INSTALL MUD RING AS SHOWN. USE FIBERGLASS TAPE ON THE EDGES OF THE PERFORATED SHEET. SECURE THE MUD RING WITH 4 NAILS IN THE HOLES OF THE PERFORATED SHEET. (FIGURE 2)
3. APPLY MUDDING MATERIAL OVER THE PERFORATED SHEET AND AROUND THE TRIM COLLAR. (FIGURE 3)
5. PULL LOW VOLTAGE WIRES (24V OR 48 V DC)
6. CONNECT LOW VOLTAGE WIRES (24V OR 48V DC) TO THE DiDi DRIVER USING PROVIDED WAGO CONNECTORS. CONNECT NEUTRAL TO BLUE/WHITE AND HOT TO BROWN/BLACK. (FIGURE 4)
7. PUT THE DiDi DRIVER INSIDE THE CEILING PLENUM. THE DiDi DRIVER WILL SIT ON TOP OF CEILING. (FIGURE 5 & 6)
8. SCREW THE FIXTURE INTO THE TRIM OPENING. MAKE SURE ALL THE WIRES ARE ALL THE WAY IN THE CEILING.(FIGURE 5 & 6)
9. IF THE FIXTURE IS ORIENTABLE, ORIENT THE FIXTURE. PROCEED TO SWITCH POWER ON. (FIGURE 7)

FIXTURE INSTALLATION – LINE VOLTAGE

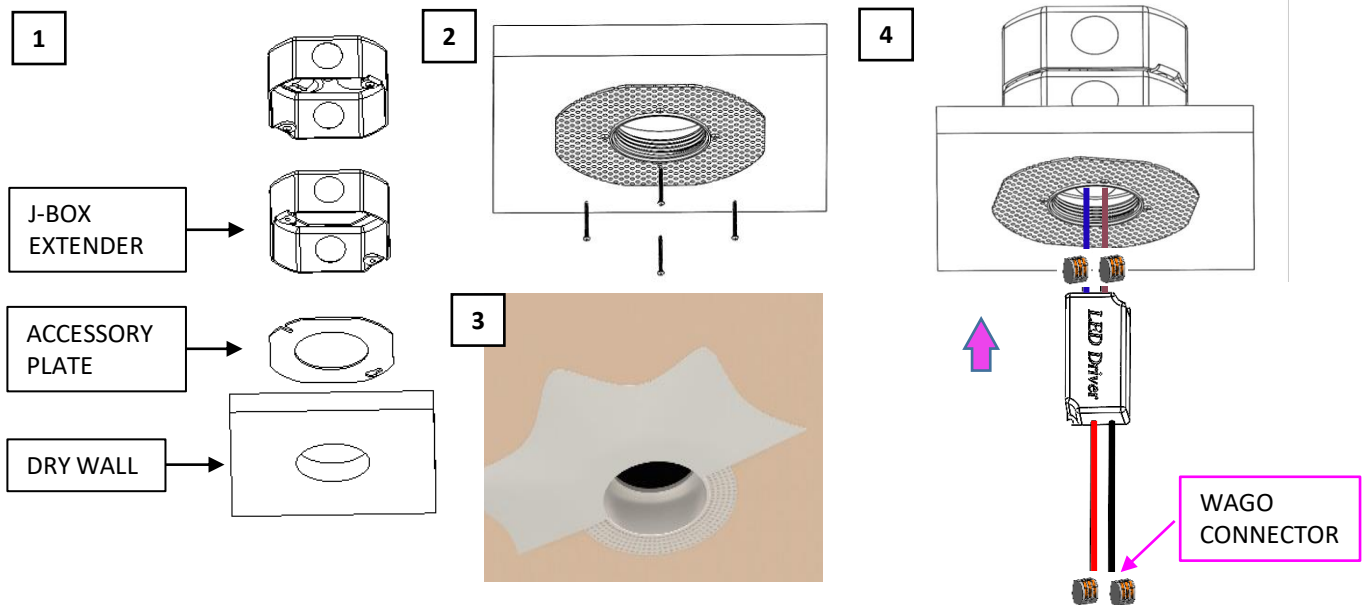

1. MAKE SURE A J-BOX EXTENDER IS USED. THE TOTAL DEPTH OF THE J-BOX SHOULD BE 3" OR MORE. (FIGURE 1)
2. CUT HOLE IN THE CEILING DRYWALL USING THE HOLE IN THE ACCESSORY PLATE AS A GUIDE. (FIGURE 1).
3. INSTALL MUD RING AS SHOWN. USE FIBERGLASS TAPE ON THE EDGES OF THE PERFORATED SHEET. SECURE THE MUD RING WITH 4 NAILS IN THE HOLES OF THE PERFORATED SHEET. (FIGURE 2) MAKE SURE THE ACCESSORY PLATE IS INSTALLED BEFORE THE CEILING GOES UP.
4. APPLY MUDDING MATERIAL OVER THE PERFORATED SHEET AND AROUND THE TRIM COLLAR. (FIGURE 3).
5. CONNECT DRIVER TO LINE VOLTAGE USING PROVIDED WAGO CONNECTORS. CONNECT NEUTRAL TO BLUE/WHITE AND HOT TO BROWN/BLACK. (FIGURE 4)

FIXTURE INSTALLATION – LINE VOLTAGE

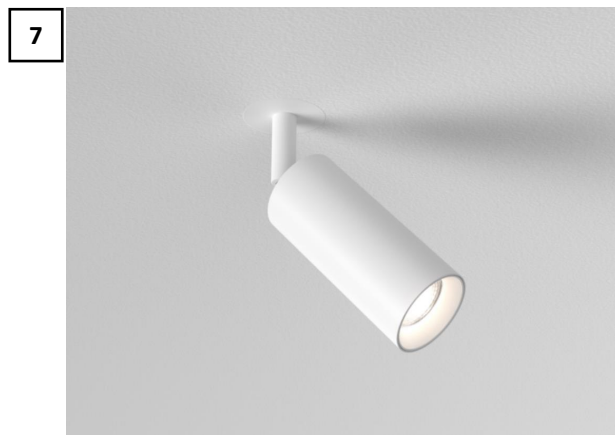
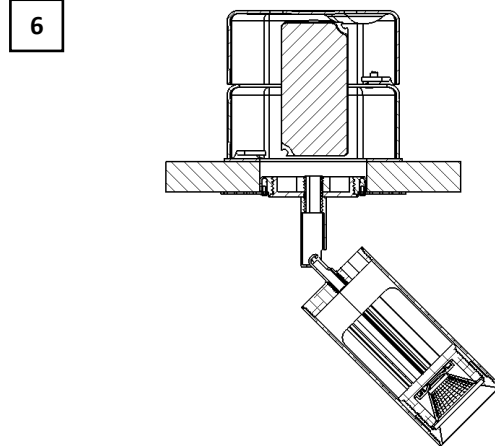
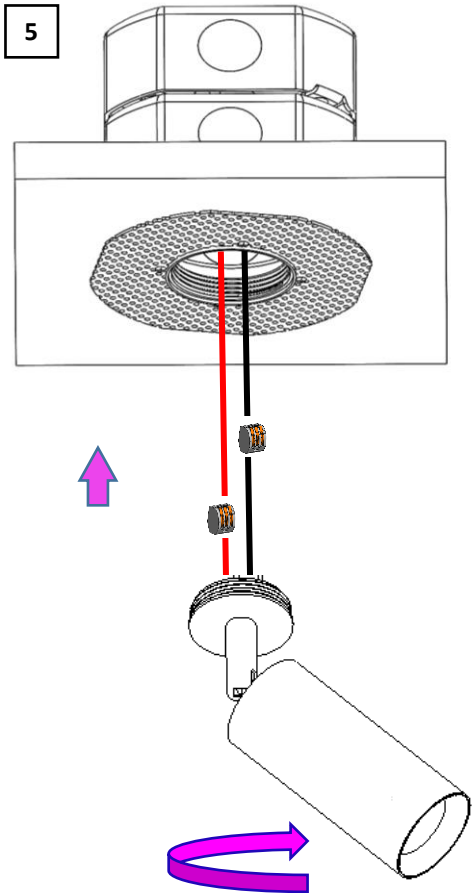

6. CONNECT THE DRIVER TO THE GEM FIXTURE USING THE WAGO CONNECTER. CONNECT RED TO RED AND BLACK TO BLACK. (FIGURE 5)
7. INSERT THE DRIVER IN J-BOX. ZANIBONI DRIVER WILL SIT INSIDE THE J-BOX. MAKE SURE THE WAGO CONNECTORS ARE ACCOMODATED INSIDE THE J-BOX (FIGURE 5 & 6)
8. SCREW THE FIXTURE INTO THE TRIM OPENING. MAKE SURE ALL THE WIRES ARE ALL THE WAY IN THE J-BOX.(FIGURE 5 & 6)
9. IF THE FIXTURE IS ORIENTABLE, ORIENT THE FIXTURE. PROCEED TO SWITCH POWER ON. (FIGURE 7)